

General Description

The MP1015 is a Power IC that offers a true complete solution for driving a Cold Cathode Fluorescent Lamps (CCFL). This Power IC converts unregulated DC voltage to a nearly pure sine wave required to ignite and operate the CCFL. Based on proprietary power topology and control techniques (patented), it greatly increases the power conversion efficiency. The MP1015 can be used with **analog** or **burst mode** dimming without any additional external components. The MP1015 offers four distinct performance advantages:

1. More light for less power
2. Smallest board implementation possible
3. Low EMI emission
4. Low cost off the shelf components

Ordering Information

Part Number*	Package	Temperature
MP1015EM	TSSOP20	-20°C to +85°C
MP1015EF	TSSOP20F	-20°C to +85°C
<u>EV0001</u>	MP1015EM Evaluation Board	

* For Tape & Reel use suffix - Z (e.g. MP1015EM-Z)

Features

- Built-in Burst Mode Oscillator and Modulator
- Built-in Analog and Burst Mode Dimming
- Built-in Current and Voltage Feedback Control
- Built-in Open/Short Lamp Protection
- Built-in Dual Mode Fault Timer
- Built-in Soft-on/Soft-off Burst Mode
- Automatic Recovery from ESD Event
- Wide Range 6 to 22V Battery Voltage with Regulated Lamp Current
- Startup at all voltages and temp without additional components
- Integrated 0.10Ω Power Switches
- Output Short Circuit Protected
- No High Voltage Ballast Capacitor
- **Evaluation Board Available**

Applications

- LCD Backlight inverter for notebook computers, Web Pads, GPS, or desktop display

Figure 1: Typical Circuit for PWM or Analog Mode Operation (includes all protection requirements)

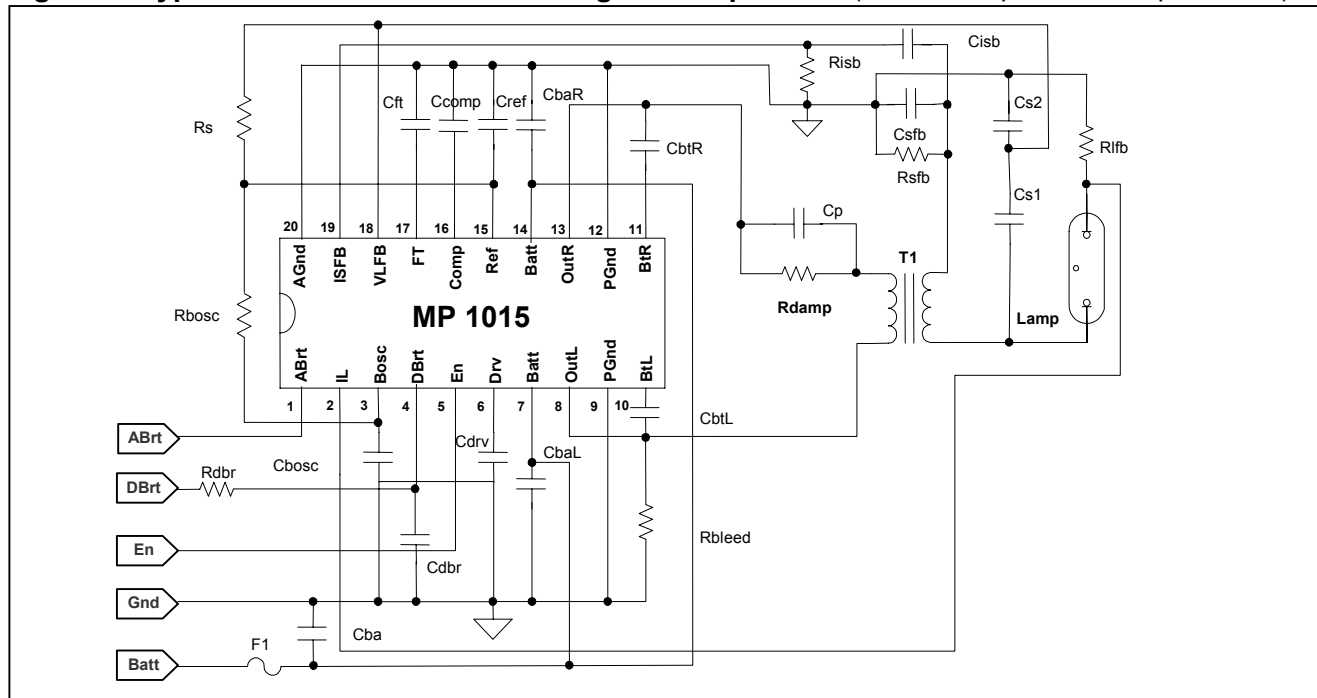

Absolute Maximum Ratings

Input Voltage (V_{Batt})	25V
IL, ISFB Input Voltages (V_{IL} , V_{ISFB})	+/-6V
VLFB Input Voltage (V_{VLFB})	-0.3 to 12V
Logic Input Voltages	-0.3 to 6.8V
Power Dissipation	1.0W
Operating Frequency	150KHz
Junction Temperature	150°C
Lead Temperature (Solder)	260°C
Storage Temperature	-55°C to 150°C

Recommended Operating Conditions

Input Voltage (V_{Batt})	6 to 22V
Analog Brightness Voltage (V_{ABrt})	0 to 1.9V
Digital Brightness Voltage (V_{DBrt})	0 to 1.8V
Enable (V_{En})	0 to 5V
Operating Frequency (Typical)	60KHz
Ambient Operating Temperature	-20°C to +85°C

Thermal Characteristics

Thermal resistance θ_{JA} (TSSOP)	140°C/W
Thermal resistance θ_{JA} (TSSOPF)	110°C/W

Electrical Characteristics (Unless otherwise specified $V_{Batt}=12V$, $T_A=25^\circ C$)

Parameters	Symbol	Condition	Min	Typ	Max	Units
Reference Voltage						
Output Voltage	V_{Ref}	$I_{Ref} = 3mA$	4.75	5.0	5.25	V
Reference Current	I_{Ref}				3.0	mA
Line Regulation		$6.5V < V_{Batt} < 22V$			30	mV
Load Regulation		$0 < I_{Ref} < 3.0mA$			30	mV
Battery Supply						
Supply Current (disabled)	I_{Batt}				10	μA
Supply Current (enabled)	I_{Batt}	$6.0V < V_{Batt} < 22V$		1.6	2.5	mA
Shutdown Logic						
Fault Timer Threshold	$V_{(TH)FT}$		1.1	1.2	1.3	V
Fault Timer Sink Current		$V_{VLFB} > 0, V_{ISFB} < 1.2V$		1		μA
Fault Timer Source Current						
Open Lamp		$V_{VLFB} < 0, V_{ISFB} < 1.2V$		1		μA
Secondary Overload		$V_{ISFB} > 1.2V$		120		μA
Enable Voltage Low	$V_{(L)En}$				0.5	V
Enable Voltage High	$V_{(H)En}$		2.0			V
Output Drivers						
Switch On Resistance	$R_{(ON)OutL,OutR}$	(Note 1)	0.085	0.12	0.15	Ω
Short Circuit Current	I_{SC}			4		A
Ton(min)		$V_{Comp}=0V, V_{Batt}=22V$		435	550	ns
Ton(min)		$V_{Comp}=0V, V_{Batt}=6V$		1750	2100	ns
Brightness Control						
Sense full Brightness	V_{IL}	$V_{ABrt} = 2.0V$	360	379	400	mV
Sense full Dim	V_{IL}	$V_{ABrt} = 0V$	105	117	130	mV
Lamp Current regulation		$7V < V_{Batt} < 22V$		2	5	%
Burst Oscillator Sink Current	I_{Bosc}			380		μA
Burst Oscillator Peak Voltage	V_{Bosc}		1.7	1.8	1.9	V
Digital Brightness Offset Voltage	$V_{(OS)DBrt}$		-50	5	50	mV
Fault Loop Control						
Open Lamp Threshold	$V_{(TH)VLFB}$			0		V
Secondary Current Threshold	$V_{(TH)ISFB}$			1.2		V
Fault Mode Comp Current	I_{Comp}	$V_{VLFB} < 0V, V_{ISFB} > 1.2V$		475		μA

Note 1: This parameter is guaranteed by design.

Pin Description

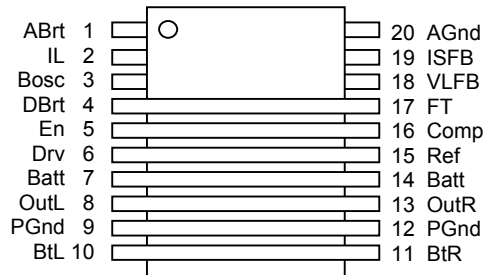
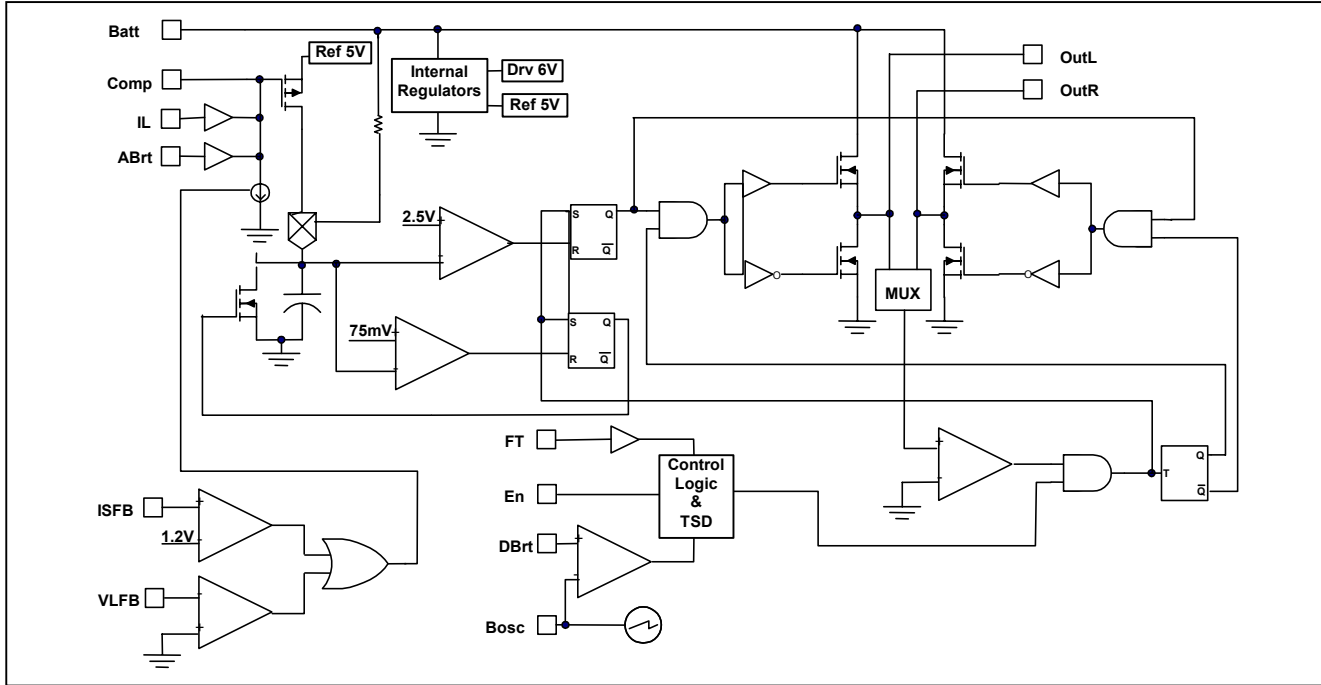

Table 1: Pin Designators

Pin Number	Pin Name	Pin Function
1	ABrt	Analog Dimming
2	IL	Lamp Current Feedback Sense Input
3	Bosc	Burst Oscillator Timing
4	DBrt	Burst Mode Dimming
5	En	Chip Enable. Do not float this pin.
6	Drv	Internally Generated MOSFET Gate Drive Supply Voltage (6V)
7	Batt	Power Supply Input
8	OutL	Output to Load (tank circuit)
9	PGnd	Power Ground
10	BtL	Regulated Output Voltage for Bootstrap Capacitor on Phase L
11	BtR	Regulated Output Voltage for Bootstrap Capacitor on Phase R
12	PGnd	Power Ground
13	OutR	Output to Load (tank circuit)
14	Batt	Power Supply Input
15	Ref	Internally Generated Reference Voltage Output (5V)
16	Comp	Loop Compensation Capacitor
17	FT	Fault Timer
18	VLFB	Open Lamp Detect (Lamp Voltage Feedback.)
19	ISFB	Shorted Lamp Detect (Secondary Current Feedback)
20	AGnd	Small Signal Ground (Note 1)

Note 1: For the MP1015EF, connect the exposed paddle to AGND (Pin 20).

Figure 2: Functional Block Diagram



Feature Description

Brightness Control

The MP1015 can operate in three modes: Analog Mode, Burst Mode with a DC input, or Burst Mode with an external PWM. The three modes are dependent on the pin connections as per Table 1. Choosing the required burst repetition frequency can be achieved by an RC combination, as defined in component selection. The MP1015 has a soft on and soft off feature to reduce noise, when using burst mode dimming.

Table 2: Function Mode

Function	Pin Connection		
	Pin 1	Pin 4	Pin 3
	ABrt	DBrt	Bosc
Analog Mode	0 – 1.9V	V _{Ref}	AGnd
Burst Mode with DC input voltage	V _{Ref}	0 – 1.8V	Rbosc Cbosc
Burst Mode from external source	V _{Ref}	PWM	1.5V

Brightness Polarity:

Burst: 100% duty cycle is at 1.8V
Analog: 1.9V is maximum brightness

Fault Protection

Open Lamp: The VLFB pin (#18) is used to detect whether an open lamp condition has occurred. During normal operation the VLFB pin is typically at 5V DC with an AC swing of +/- 2V. If an open lamp condition exists then the AC voltage on the VLFB line will swing below zero volts. When that occurs, the IC regulates the VLFB voltage to 10V p-p and a 1µA current source will inject into the FT pin. If the voltage at the FT pin exceeds 1.2V, then the chip will shut down.

Excessive Secondary Current (Shorted Lamp and UL safety specs): The ISFB pin (#19) is used to detect whether excessive secondary current has occurred. During normal operation the ISFB voltage is a 1V p-p AC signal centered at zero volts D.C. If a fault condition occurs that increases the secondary current, then the voltage at ISFB will be greater than 1.2V. When that occurs, the IC regulates the ISFB voltage to 2.4V p-p and a 120µA current source will inject into the FT pin. If the voltage at the FT pin exceeds 1.2V, then the chip will shut down.

Feature Description (continued)

Fault Timer: The timing for the fault timer will depend on the sourcing current, as described above, and the capacitor on the FT pin. The user can program the time for the voltage to rise before the chip detects a “real” fault. When a fault is triggered, then the internal drive voltage (V_{Dr}) will collapse from 6.2V to 0V. The reference voltage will stay high at 5.0V.

Lamp Startup

The strike voltage of the lamp will always be guaranteed at any temperature because the MP1015 uses a resonant topology for switching the outputs. The device will continue to switch at the resonant frequency of the tank until the strike voltage is achieved. This eliminates the need for external ramp timing circuits to ensure startup.

Chip Enable

The chip has an on / off function, which is controlled by the En pin (#5). The enable signal goes directly to a Schmitt trigger. The chip will turn ON with an En = High and OFF with an En = Low.

Application Information

Pin 19 (ISFB) : R_{sfb}, C_{sfb}, R_{isb} and C_{isb} (Secondary Short Protection)

The R_{sfb} and C_{sfb} combination is used for feedback to the IS pin to detect excessive secondary current. *These resistors have to be +/- 5% tolerance components.* The value for R_{sfb} is approximately 1.7KΩ and C_{sfb} is approximately 82nF. This will ensure that the voltage at the ISFB pin is typically 1.0V during steady state operation. The maximum value for C_{sfb} is 93nF to ensure that the chip will meet the UL1950 specification. R_{isb} and C_{isb} components are used as a high pass filter.

Pin 18 (VLFB): C_{s1}, C_{s2} and R_s (Open Lamp protection)

The regulated open lamp voltage is proportional to the C_{s1} and C_{s2} ratio. C_{s1} has to be rated at 3KV and is typically between 5 to 22pF. The value of C_{s1} is typically 15pF and is chosen for a specified maximum frequency. The value of C_{s2} is set by the

Customer to achieve the required open lamp voltage detection value, typically 4nF.

$$C_{s2} = C_{s1} * V_{(max)rms} / 3.5V_{rms}$$

The value of R_s is typically 300KΩ (not critical).

Pin 17 (FT): C_{ft}

The C_{ft} cap is used to set the fault timer. This capacitor will determine when the chip will reach the fault threshold value. The user can choose the cap value to set the time out value.

Open Lamp Time

$$C_{ft} (nF) = T(\text{open lamp}) (1\mu A) / 1.2 V$$

For a C_{ft}= 820nF, then the time out for open lamp will be 0.98 sec.

Secondary Short Turn Off time

Because the sourcing current for a secondary short is approx. 120μA, then the off time when a resistive short occurs across the lamp will be approx 100 times faster than the open lamp time.

To reduce the turn off time even further, then by modifying the connection at the FT node to:

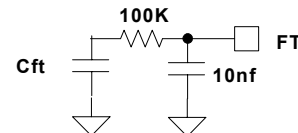

Figure 3: Turn Off Time Adjustment

For a Cap=10nF, then the time out for secondary short will be 0.11ms. The turn off time for the secondary short will be reduced by an additional 100 times.

Note: The open lamp time will remain the same value as defined by C_{ft}.

Pin 16 (Comp): C_{comp}

This cap is the system compensation cap that connects between comp and AGnd. A 1.5nf or 2.2nF cap is recommended. This cap should be X7R ceramic with a voltage rating sufficient for 5V biasing. The value of C_{comp} affects the soft-on rise time and soft-off fall time.

Application Information (Continued)

Pin 15 (Cref):

Cref is the bypass cap for the internal 5.0V supply. This capacitor must be placed as close as possible to the pin. A maximum of 100 mils is recommended between the cap and the IC. The value of the cap is typically 0.47 μ F

Pin 14, Pin 7 & Pin 9 (Batt & PGnd): CbaR/L, Cba

These caps are used as the bypass caps for the battery voltage supply line. These capacitors will absorb most of the input switching current of the inverter and will require adequate ripple rating. The typical current rating for Cba is > 500mArms. Typically CbaR and CbaL are 1 μ F and Cba is equal to 2 caps of 2.2 μ F.

Pin 13 & Pin 8 (OutL & OutR): Cp1, Rdamp, Rbleed

The primary transformer current flows through this capacitor. Its value is typically 1 μ F and its voltage rating is sufficient for a 5V bias. The capacitor should be ceramic and have a ripple current rating greater than the primary current (typically 0.8Arms). It is more optimal to use two parallel 0.47 μ F ceramic caps for minimal ESR losses.

Rdamp and Rbleed are used to ensure that the bridge outputs are at 0V prior to startup. Typically Rbleed = 4.3K Ω and Rdamp = 1K Ω .

Pin 11 and Pin 10 (BtL and BtR): Cbtl and Cbtr

These are the reservoir caps for the upper switches' gate drive. They should be 10nF and made of X7R ceramic material and have a voltage rating for 6.6V biasing.

Pin 6 (Drv): Cdrv

This bypasses the 6.2V gate supply for the lower switches. The value should be 100nF ceramic Y5V or X7R material.

Pin 5: (En)

This pin will enable and disable the chip. Do not float this pin.

Pin 4 (DBrt) : Rdbr, Cdbr

This pin is used for burst brightness control. The DC voltage on this pin will control the burst percentage on the output. The signal is filtered for optimal operation. The active range is approximately 0.1V to 1.8V. The value of Rdbr and Cdbr is not critical.

Pin 3 (Bosc): Cbosc, Rbosc

The Cbosc and Rbosc will set the burst repetition rate and the minimum Ton. Set T_{min} to achieve the minimum required system brightness. Ensure that T_{min} is long enough that the lamp does not extinguish. These values are determined by the following steps:

- 1) Select a Minimum Duty Cycle (D_{MIN}). This is the ratio T_{FALL} / (T_{FALL} + T_{RISE}) for the burst oscillator. For example: 10%
- 2) Determine Rbosc by the formula:

$$R_{bosc} = \frac{\left[\frac{1.68 * [(1 / D_{MIN}) - 1]}{0.42} \right] + 4}{350 * 10^{-6}}$$

- 3) Select a burst frequency and find T_{TOTAL} where T_{TOTAL} = 1/burst frequency. Then determine Cbosc by the formula:

$$C_{bosc} = \frac{(1 - D_{MIN})}{0.42 * R_{bosc} * f_{bosc}}$$

Where:

f_{bosc} = burst frequency rate in Hz
T_{min} = Minimum burst time in sec

Figure 4: Open_Lamp Voltage Setup and UL Test Protection Application Information

When the Vpk of VLFB is below 0V, open_lamp protection will work.

So, Open_Lamp Voltage will be set by
Open_Lamp Voltage (rms) = $Cs2 / Cs1 * 3.5 \text{ Vrms}$

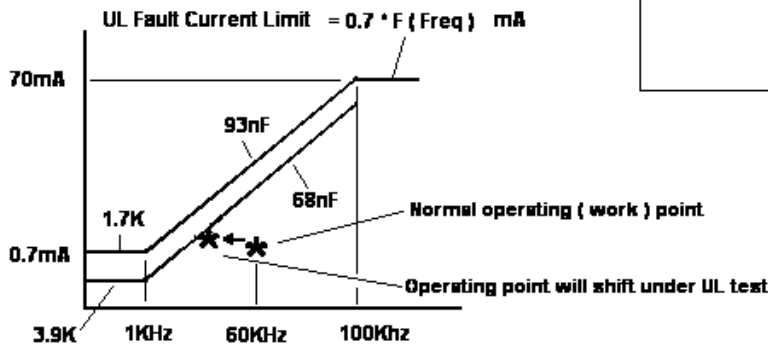
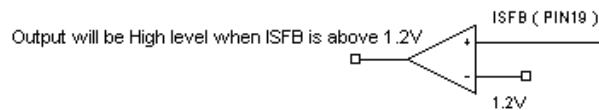
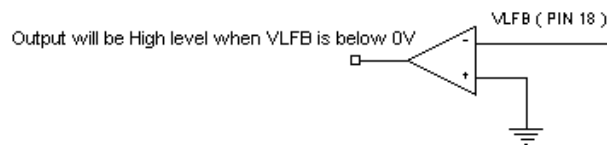
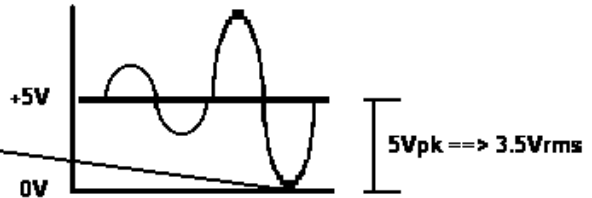

When V_ISFB is above 1.2V, UL protection will work.

So, $X_{csfb} = E / I = E_{pk} / I_{pk} = 1.2V / 70mA$

$X_{csfb} = 1 / (2 * 3.14 * F * C_{sfb}), F = 100K$

$C_{sfb} = 1 / (2 * 3.14 * 100K * X_{csfb}) = 70mA / (2 * 3.14 * 100K * 1.2V) = 93nF$

Get $C_{sfb_max} = 93nF$, therefore C_{sfb} is selected below 93nF approx 75nF or 68nF.

$R_{sfb} = E / I = 1.2V / 0.7mA = 1.7K$

Get $R_{sfb_min} = 1.7K$, therefore R_{sfb} is selected above 1.7K approx 12K ~ 3.9K.

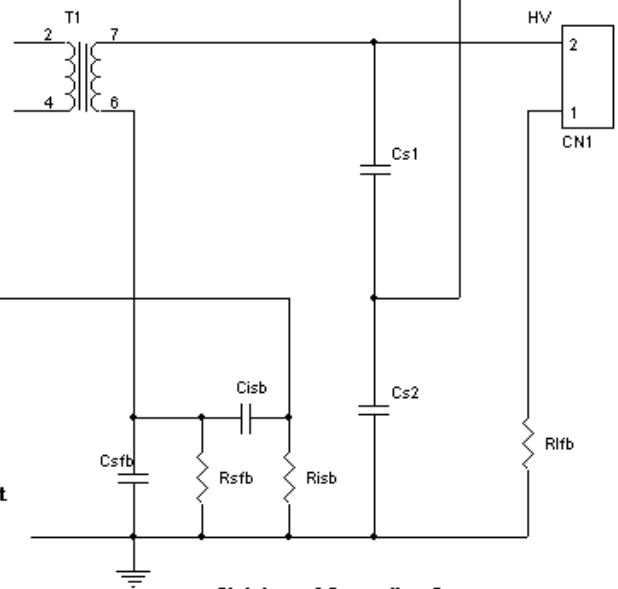
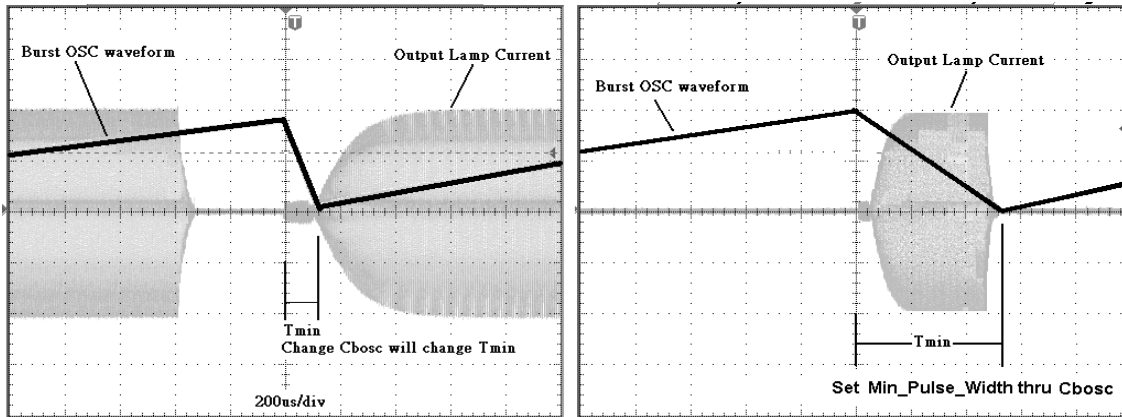
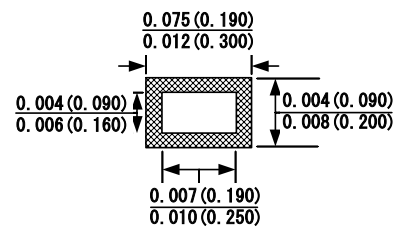
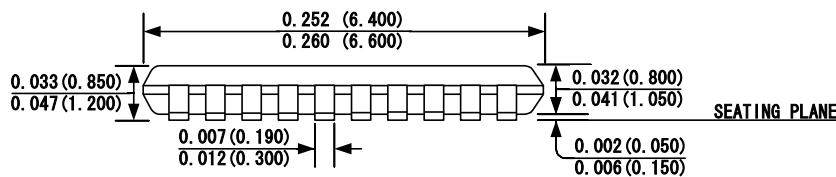
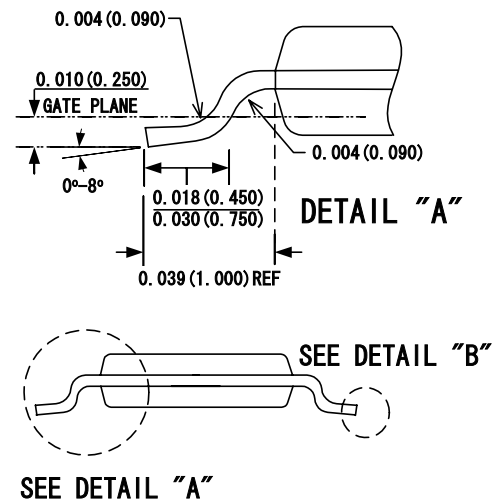
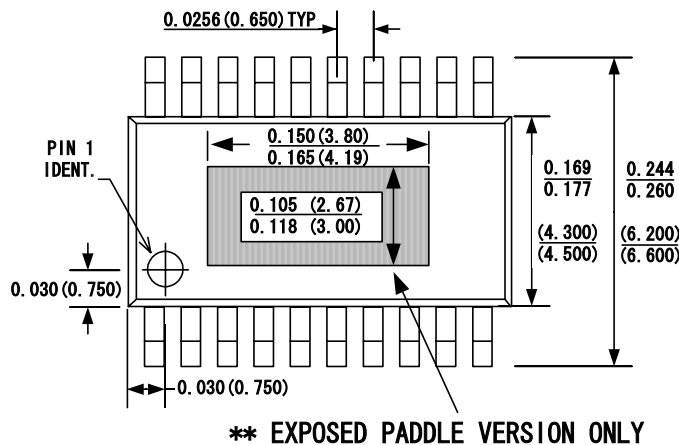

Figure 5: Burst Oscillator Waveform versus Output Lamp Current



Packaging Information

TSSOP20 or TSSOP20F (Exposed Paddle **)



NOTE:
1) Control dimension is in inches. Dimension in bracket is millimeters.

NOTICE: MPS believes the information in this document to be accurate and reliable. However, it is subject to change without notice. Please contact the factory for current specifications. No responsibility is assumed by MPS for its use or fit to any application, nor for infringement of patent or other rights of third parties.